

**RAYNOR®**  
**THERMASEAL™**  
SECTIONAL THERMAL DOORS



ThermaSeal STANDARD, white, with oval window

M A X I M U M  
T H E R M A L  
P R O T E C T I O N

**RAYNOR®**  
**GARAGE DOORS**  
*Built to be worry free.™*

**RAYNOR®**  
**THERMASEAL™**  
 SECTIONAL THERMAL DOORS

Introducing ThermaSeal™ — our durable, energy-efficient sectional door. Our exclusive process fills 100% of the door's interior space with energy-saving polyurethane foam insulation to deliver exceptional R-values. This process also provides superior foam density for excellent structural integrity. For maximum thermal protection, choose ThermaSeal.

**ThermaSeal STANDARD**

With a 16.4 R-value, this benchmark product provides proven Raynor reliability and durability to meet or exceed the requirements of daily use. This door is offered with the widest selection of quality features and options for the most common product applications.

**ThermaSeal BASIC**

Practical when thermal performance is desired but cost is a consideration, this door is available in a limited selection of sizes, features and options.



ThermaSeal BASIC, white, with oval windows

Series MODEL	Max. Opening Width	Max. Opening Height	Construction	Surface Texture	Section Thickness	Exterior/Interior Steel Thickness	End Stile Steel Thickness	Insulation (R-Value)	Thermal Break	Exterior Colors	Section Warranty
ThermaSeal STANDARD	28'	20'	Steel Sandwich	Stucco	13/4"	25-Gauge (.019")/ 26-Gauge (.016")	16-Gauge (.055" min.)	Polyurethane Foam (16.4)	Yes	White, Dark Brown	1-Year (Any Rust) 10-Year (Delamination)
ThermaSeal BASIC	16'	16'	Steel Sandwich	Stucco	11/2"	26-Gauge (.016")/ 26-Gauge (.016")	16-Gauge (.055" min.)	Polyurethane Foam (14.5)	Yes	White	1-Year (Any Rust) 10-Year (Delamination)

**WARRANTY** ThermaSeal door sections carry a 1-year limited warranty against any rust and a 10-year limited warranty against delamination (of the steel door skins from the insulating foam). Hardware and springs are warranted for 1 year against defects in materials and workmanship. See your local Raynor Dealer for complete details.

## MODEL OPTIONS AND UPGRADES

### ① Choice of windows.

Select either 24" x 8" oval (shown) or aluminum full-view window sections. Choose from a variety of insulated glass, acrylic and polycarbonate styles to suit any application.



### ② High-cycle counterbalance systems.

For reliable operation in high-traffic areas, choose high-cycle torsion springs with 25,000, 50,000 or 100,000-cycle life.\* For reduced maintenance and ultra-smooth operation in heavy-use applications, choose a weight counterbalance system.



### ③ Perimeter seal.

Header and jamb (shown) seals help to decrease energy costs and reduce air infiltration by sealing the top and sides of the door when closed.



### ④ Locks.

In applications where control and access are important, choose from a variety of locking options to help keep your building secure. Locks come in both inside and outside variations.



### ⑤ Customized track and hardware systems.

Track systems are supplied to fit special clearances, inclines or contour applications. Hardware and track systems can be designed to fit any need.\* Additional trussing is available for special windloading applications.

### ⑥ Pedestrian doors.

Pedestrian doors are designed for convenient entry and to help minimize energy loss.\*

### ⑦ Removable center posts.

Carry-away and swing-up options are available for extra-wide openings. Ideal for agricultural or airplane hangar applications.

### ⑧ Carbon monoxide vent.

Allows you to channel fumes to the outside when door is closed. Available in a variety of sizes.

\* Some options may be limited to door size or model. Contact your local Raynor Dealer regarding availability for your application.

POWERHOIST™ OPERATORS



**PowerHoist operators.**

Raynor offers a full line of rugged PowerHoist operators. Trolley operators (top) are mounted overhead and suspended from the ceiling. Jackshaft operators (middle) are side-mounted and attached to the wall. Manual chain operation is also available.

**Control options.**

A variety of control stations, photoelectric eyes and remote activation devices are available.

White

All ThermaSeal doors are available in White.

Dark Brown

ThermaSeal STANDARD doors may be upgraded to Dark Brown. This color features the Kynar™ paint process, which provides extended UV protection against fading.

Every ThermaSeal door is built for superior performance and includes the features listed below. For additional options, please see the inside pages.



1

**Maximum thermal protection.**

Energy-saving polyurethane foam insulation is used to deliver exceptional R-values.

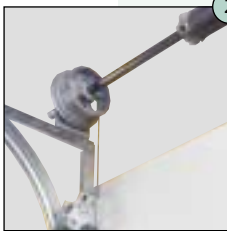

2

**Rugged hardware and springs.**

Your ThermaSeal door comes packaged with the right combination of long-lasting hardware, track and springs to precisely match your door's size and application.



3

**Reduced airflow.**

Dual vinyl barriers dramatically reduce air infiltration. A true thermal break prevents heat loss and eliminates any metal-to-metal contact between surfaces.

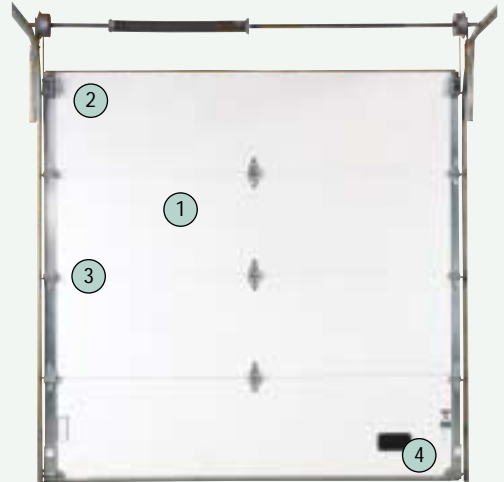

4

**Decreased energy costs.**

ThermaSeal doors help you reduce energy costs with a U-shaped, vinyl bottom weatherseal and sturdy aluminum retainer.

**Built tough.** Rust-resistant galvanized steel is finished with a two-coat, baked-on paint process for long life. The superior thermal bond between steel and polyurethane foam is warranted against delamination for ten years.

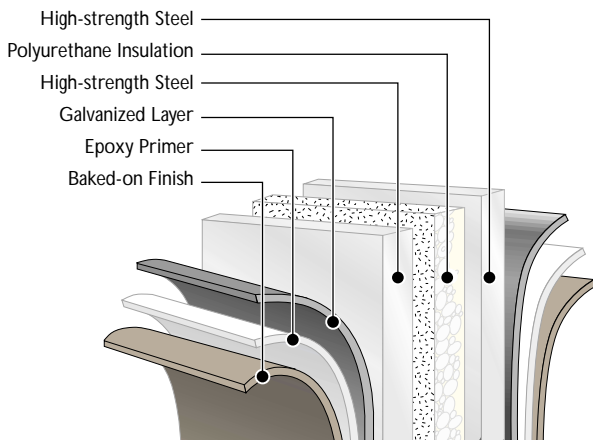

APPLICATION GUIDE

	ThermaSeal STANDARD	ThermaSeal BASIC
Agricultural Buildings	●	◐
Car Wash/Corrosive Environments	◐	○
Commercial/Multi-Tenant	●	●
Fire Station/Ambulance	●	◐
High Security	●	●
Large Opening Size	●	◐
Mining, Pulp & Paper	◐	◐
Noninsulated Storage	○	○
Service Station	◐	◐
Thermal Environments	●	●
Transit Facility/Truck Terminal	●	◐
Underground Parking	○	○
Warehouse/Manufacturing	●	●

● Best Choice   ◐ Good Solution   ○ Applicable



**Depend On Professional Installation  
By Your Raynor Dealer**

When you select Raynor, you're not just getting a superior commercial door, you're getting professional door installation and service expertise.

Every Raynor door is installed by an experienced Raynor professional. And that means added benefits for you. Because it's done right the first time, your door will deliver performance and reliability from

the day it's installed. Your technician will check your door for everything from safety to performance to appearance.

Trust your Raynor door to someone who knows it better than anyone else — your professional Raynor Dealer. We have over 600 authorized dealers serving North America and over 50 countries worldwide.

**Raynor also offers** a full line of rolling service, fire and traffic doors as well as security grilles and counter shutters. See your Raynor Dealer or visit [www.raynor.com](http://www.raynor.com) for more information.



**RAYNOR®**  
**GARAGE DOORS**

*Built to be worry free.™*

Raynor Worldwide P.O. Box 448, 1101 East River Road, Dixon, IL 61021-0448

**CALL**  
**1-800-4-RAYNOR**

**CLICK**  
**[www.raynor.com](http://www.raynor.com)**

**FAX**  
**1-815-288-7142**

Exclusively Distributed By:



This information was as complete and factual as possible at the time it was printed. We do, however, reserve the right to make changes in product specifications and availability without notice. Features and options may be different in countries other than the United States. Product colors have been reproduced as well as possible with present commercial printing processes. For absolute accuracy in color matching, use actual product samples.